

88564949 C Hall Tree Storage Bench

Dear Our Valuable Customers,

Please follow our assembly instructions in every step,
we guarantee that you will get the perfect merchandise.

Thank you so much for purchasing our quality products.



Casual Attire For Today's Home



Thai Patent Pending Numbers **081316**

BASE UNIT PART LIST



A.
Seat
1 pc.

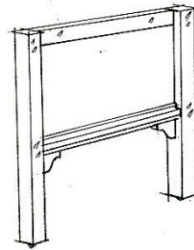

B.
Side Panel
1 pc.

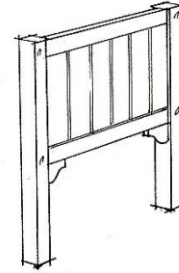

C.
Side Panel
1 pc.

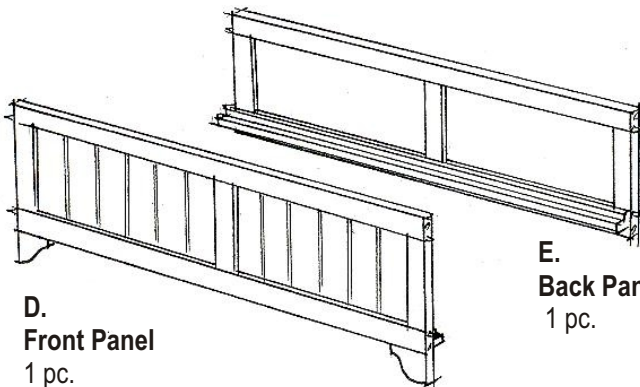

D.
Front Panel
1 pc.

E.
Back Panel
1 pc.

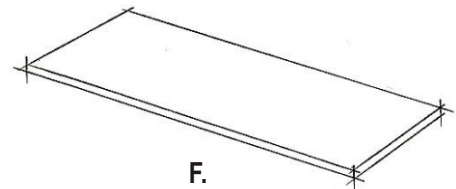

F.
Base
1 pc.

HARDWARE LIST



Hex Wrench
1 pc.



Head Cap Bolt (short)
4 pcs.(+ 1 Extra)



Cross Dowel
8 pcs.(+2 Extra)

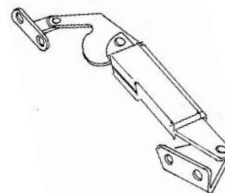

Spring Support
2 pcs.



Wood Screw (for Spring Support)
8 pcs.(+1 Extra)



Head Cap Bolt (long)
8 pcs.(+1 Extra)



Wood Plug
8 pcs. (+1 Extra)

Tools Required For Assembly : Phillips screwdriver

Assembly Instructions

IMPORTANT

Do not tighten up all the screws until each part is properly assembled.
You should keep Hex Wrench in the safe place as you may need to tighten up the Head Cap Bolts in the future.

STEP 1

Insert Cross Dowels into the holes of Front Panel (D) and Back Panel (E).

Attach the Side Panel (B) and (C) to the Front Panel and Back Panel with Head Cap Bolts.

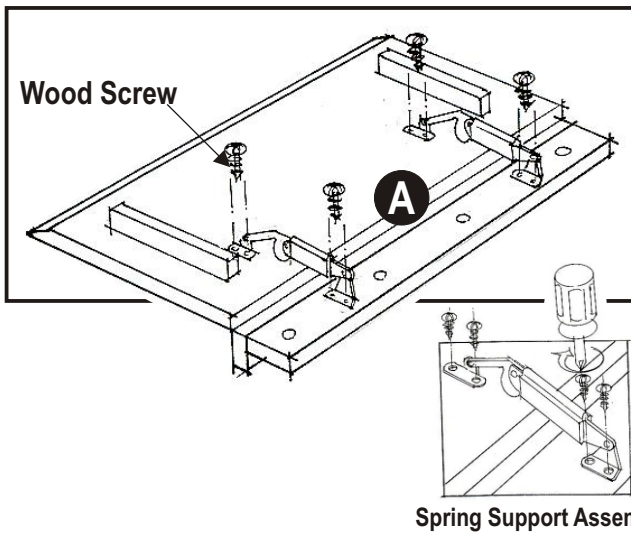
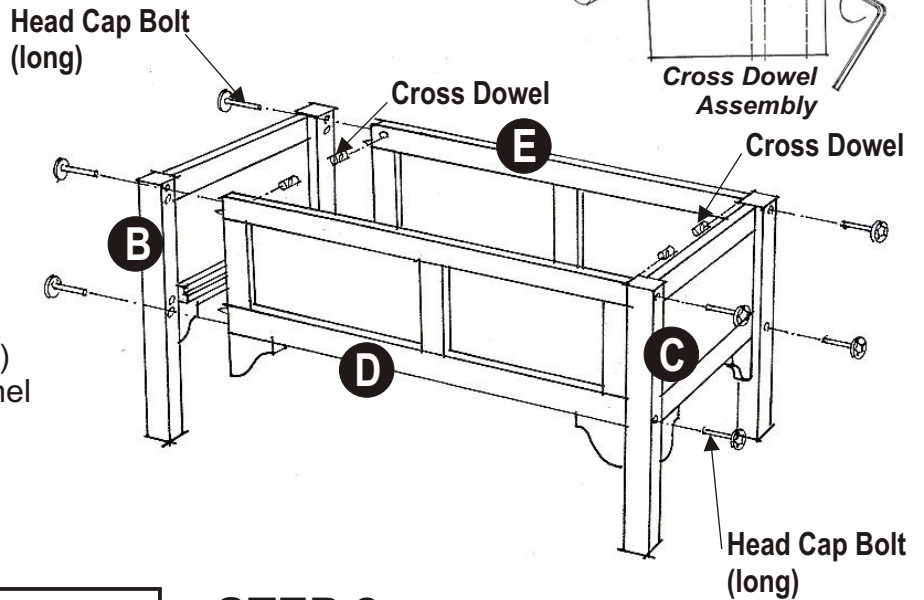

STEP 2

Turn over the Seat (A).

Attach Spring Support to the Seat (A) with Wood Screws.

STEP 3

Attach the Seat (A) to the assembled unit with Head Cap Bolts (short).

Put the Base (F) into the storage.

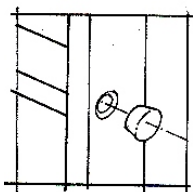
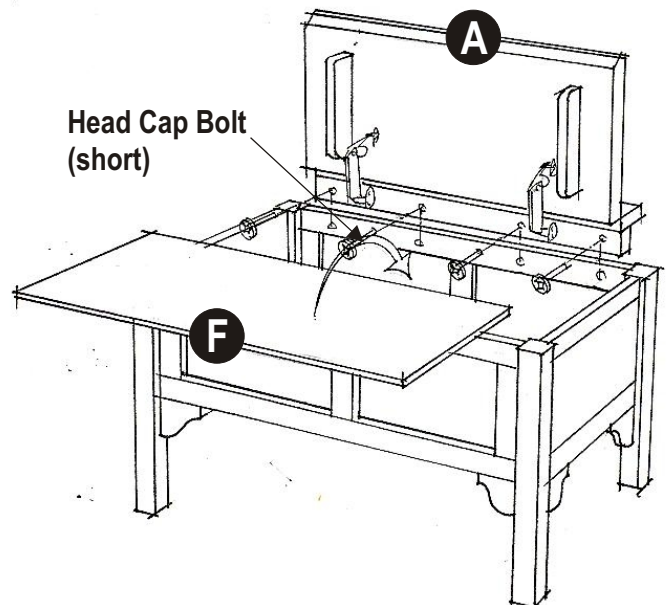

STEP 4

Cover all holes with Wood Plugs

88564949 C Hall Tree Storage Bench

Dear Our Valuable Customers,

Please follow our assembly instructions in every step,
we guarantee that you will get the perfect merchandise.

Thank you so much for purchasing our quality products.



Casual Attire For Today's Home



Thai Patent Pending Numbers **081316**

TOP UNIT PART LIST

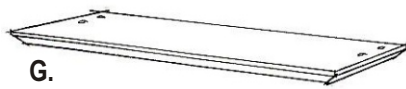

G.
Top
1 pc.

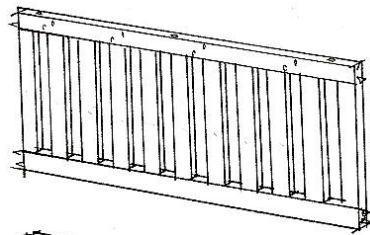

J.
**Upper
Back Frame**
1 pc.

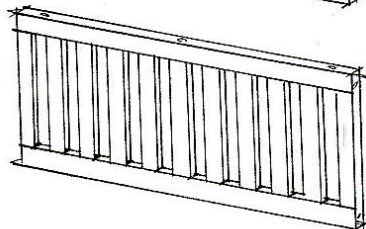

K.
**Lower
Back Frame**
1 pc.

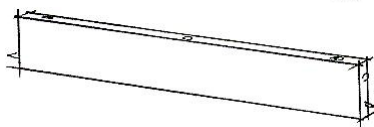

L.
Back Stretcher
2 pcs.

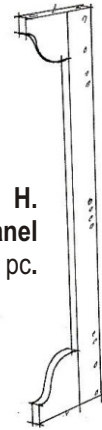

H.
Side Panel
1 pc.



I.
Side Panel
1 pc.

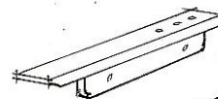

M.
Arm
1 pc.



N.
Arm
1 pc.

HARDWARE LIST

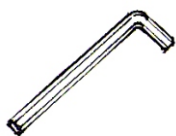

Hex Wrench
1 pc.



**Head Cap Bolt
(short)**
4 pcs.(+1 Extra)



**Head Cap Bolt
(long)**
20 pcs.(+1 Extra)



Hook
4 pcs.



Wood Screw
8 pcs.
(+1 Extra)



Wood Plug
12 pcs.
(+1 Extra)

Tools Required For Assembly : Phillips screwdriver

Assembly Instructions 2/3

IMPORTANT

Do not tighten up all the screws until each part is properly assembled.
You should keep Hex Wrench in the safe place as you may need to tighten up the Head Cap Bolts in the future.

STEP 1

Attach the Hooks to the Upper Back Frame (J) with Wood Screws.

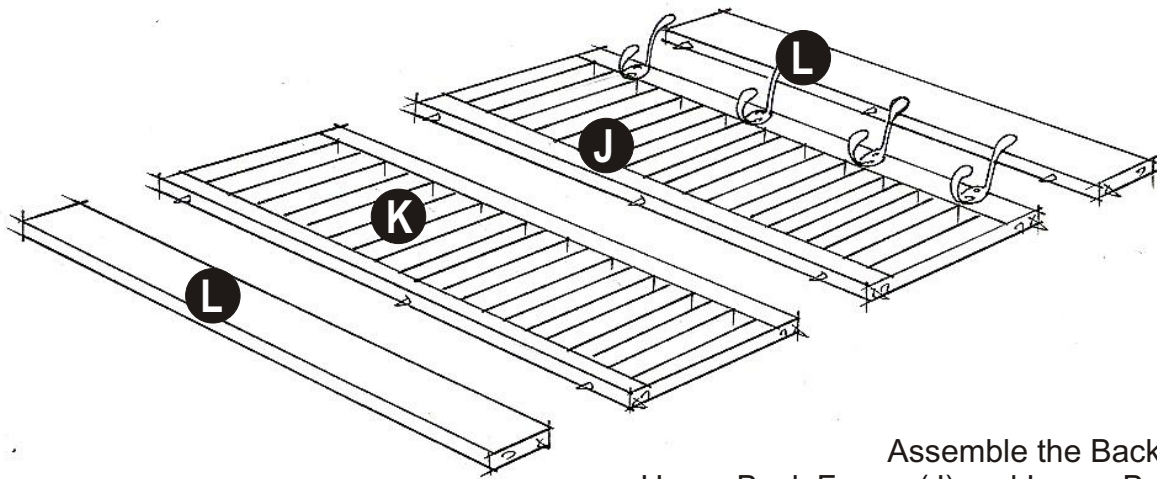
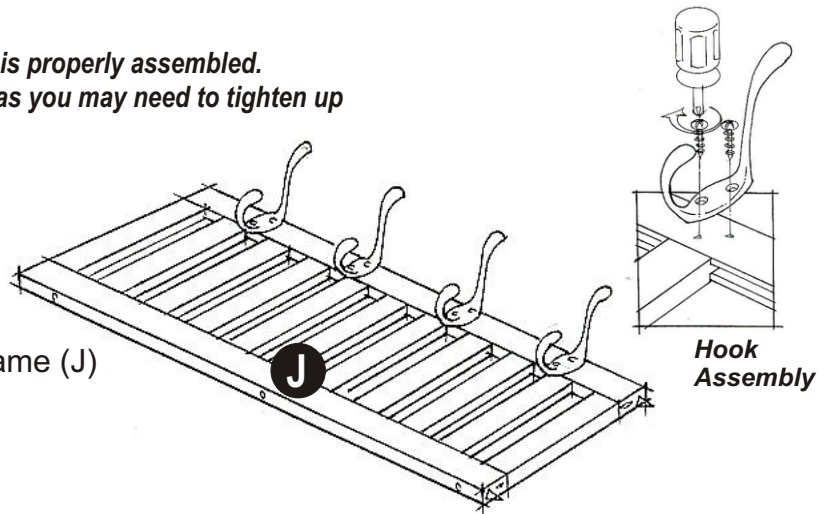

STEP 2

Assemble the Back Stretcher (L), Upper Back Frame (J) and Lower Back Frame (K).

Head Cap Bolt (long)

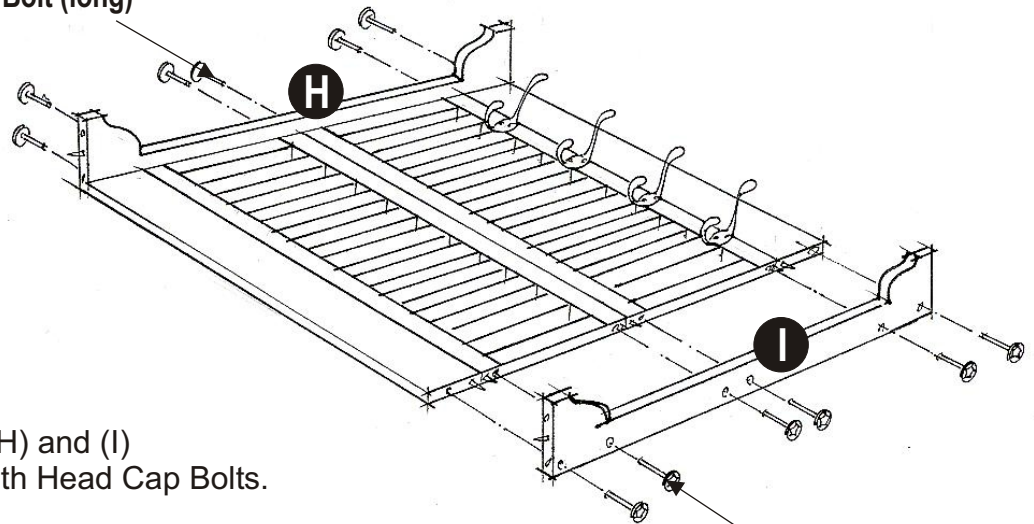

STEP 3

Attach the Side Frame (H) and (I) to the assembled unit with Head Cap Bolts.

Head Cap Bolt (long)

Assembly Instructions 3/3

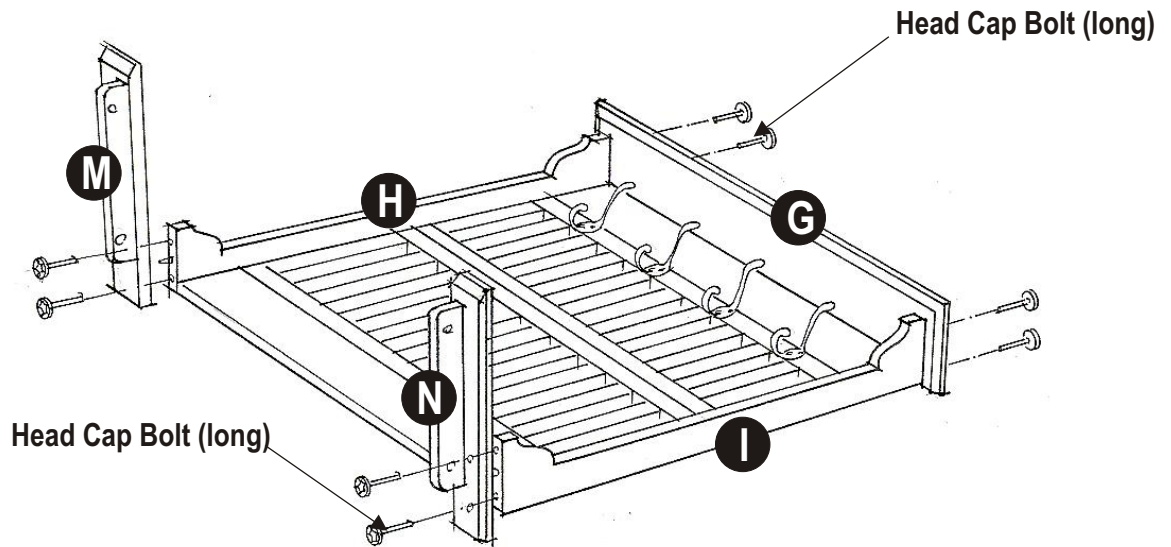

STEP 4

Attach the Top (G) to the Side Panel (H) and (I) with Head Cap Bolts as shown.

Attach the Arm (M) and (N) to the Side Panels with Head Cap Bolts.

STEP 5

Place the Top Unit on the Base Unit.

Tighten up all the Head Cap Bolts.

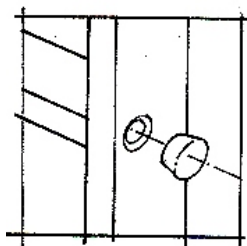
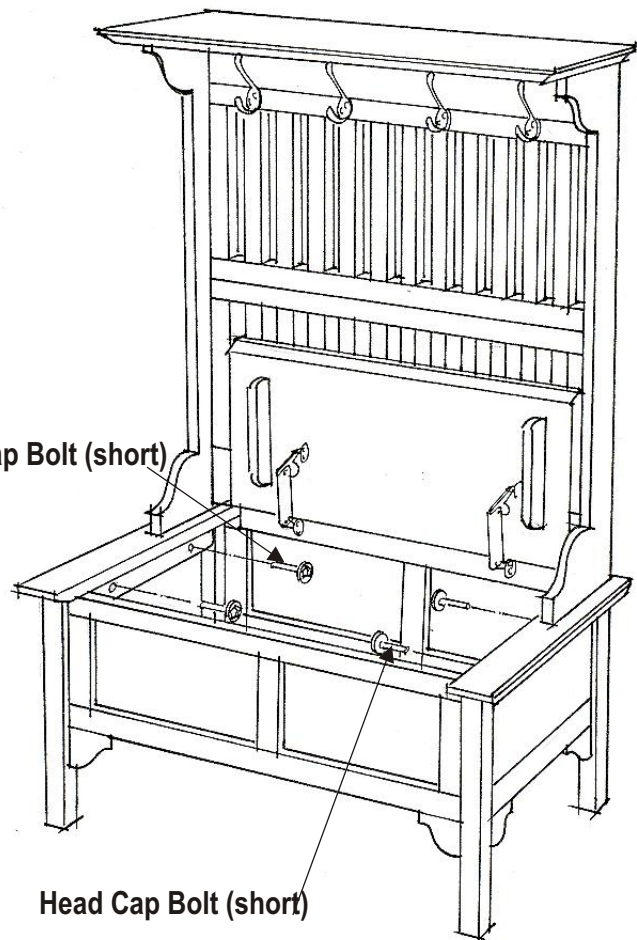

STEP 6

Cover all holes with Wood Plugs

Head Cap Bolt (short)